

DETAIL 1
SCALE 8 : 1

1. ELECTRICAL CHARACTERISTICS:
 - 1.1 CONTACT CURRENT RATING: 0.5A Min.
 - 1.2 VOLTAGE RATING: 40V AC.
 - 1.3 CONTACT RESISTANCE: 30mΩ Max.
 - 1.4 INSULATION RESISTANCE: 100MΩ Min.
 - 1.5 DIELECTRIC STRENGTH: 500V AC/1 minute.
2. MECHANICAL:
 - 2.1 INSERTION FORCE: 4.5 kgf Max.
 - 2.2 WITHDRAWAL FORCE: 1.0-4.0 kgf Min.
3. ENVIRONMENTAL:
 - 3.1 OPERATING TEMPERATURE: -25°C TO +85°C

TABLE2:

Z	材 質
0	BRASS(C2680-1/2H), T=0.30±0.02mm
1	SPCC T=0.30±0.02mm

TABLE:

XX	電 鍍
11	G.F/TIN PLATED前金后錫
12	3u" G./TIN PLATED前金后錫
13	5u" G./TIN PLATED前金后錫
14	10u" G./TIN PLATED前金后錫
15	15u" G./TIN PLATED前金后錫
16	20u" G./TIN PLATED前金后錫
17	30u" G./TIN PLATED前金后錫
18	50u" G./TIN PLATED前金后錫

TABLE1:

Y	材 質
0	LCP UL 94 V-0(抽粒料)
1	PBT+30%GF UL 94 V-0(抽粒料)

TABLE3:

A	電 鍍
無	50U" NICKEL PLATED
1	1U" 金
2	3U" 金
3	2U" 金

Build of material:

項次	名 稱	料 號	材 質	電鍍或顏色	數量	備 註
1	HDMI公頭(mold)-單件式(-)	DP1900007-5XXY	PHOSPHOR BRONZE(C5210-EH), T=0.30±0.02mm	SEE TABLE	9	
			SEE TABLE 1	BLACK	1	
2	HDMI公頭(mold)-單件式(二)	DP1900007-6XXY	PHOSPHOR BRONZE(C5210-EH), T=0.30±0.02mm	SEE TABLE	10	
			SEE TABLE 1	BLACK	1	
3	HDMI公頭(mold)-外殼	DP1900007-1ZA	SEE TABLE 2	SEE TABLE 3	1	
4	HDMI公頭(mold)-膠心	DP1900007-2Y	SEE TABLE 1	BLACK	1	

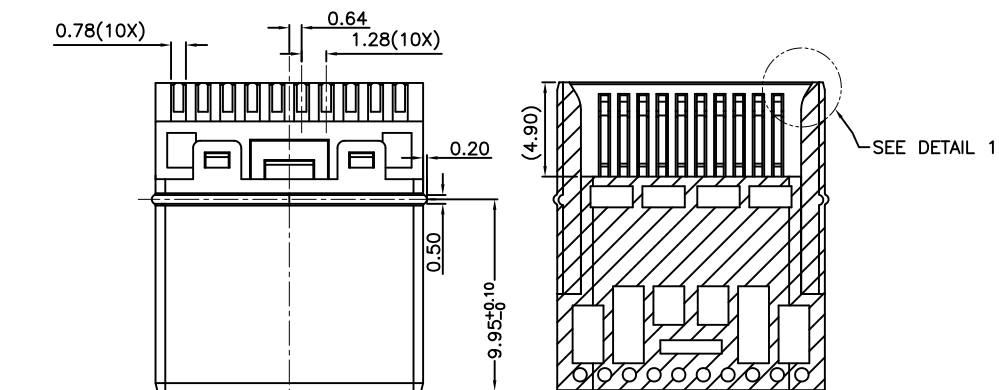

SECTION A-A

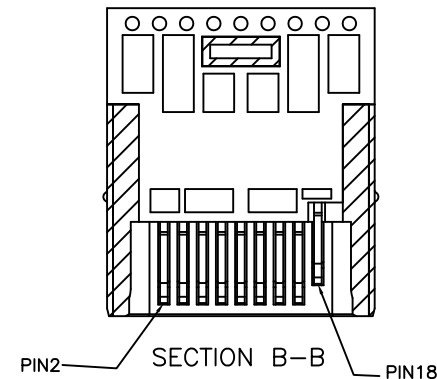
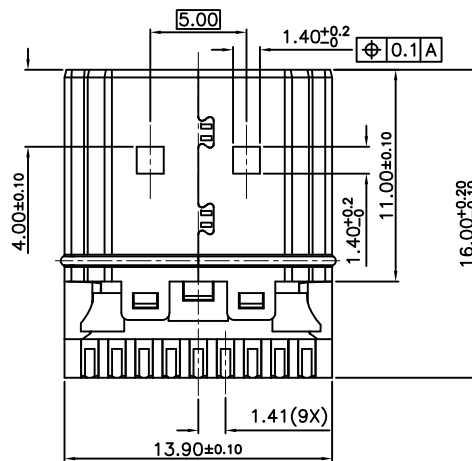
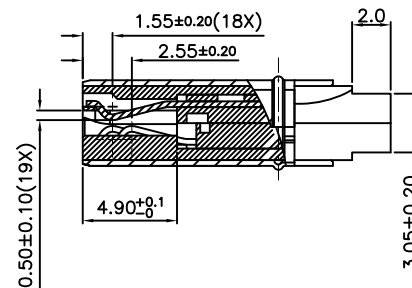
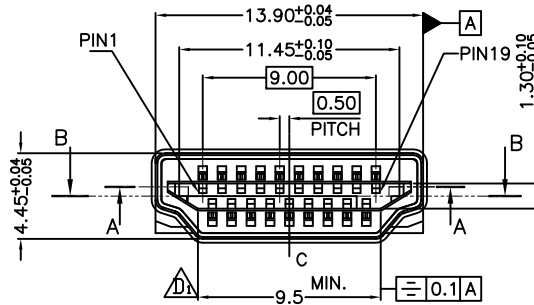

SECTION B-B

東莞世華電子有限公司
 SHYH HWA ELECTRONICS CO.,LTD.(DONGGUAN)
 地址:東莞市塘廈鎮諸佛嶺178工業區
 TEL:0769-7910020-1 FAX:0769-7910210

DRAWN BY 曹 浩
 CHECKED BY
 APPROVED BY

ITEM HDMI公頭(mold)有壓筋
 PART NO DP1900007-XXYZA
 TOLERANCE X±0.2
 .XX±0.10

ANGLE PROJECTION UNIT MM
 SCALE 2.5:1
 DATE 02/18/2011

修訂圖面
 DESCRIPTION
 DATE 02/18/2011