

REV	DESCRIPTION	ECN/ECR	DATE	DRAWN BY
△	新訂圖面	—	07/08/2015	唐忠洪

PICK&PLACE AREA
D/C(年/周/星期)

NOTES:
1. MATERIAL:
1-1: HOUSING: LCP(3040G/E6808/E6006); UL 94V-0, COLOR: BLACK
1-2: TERMINAL: BRASS(C2680-H); T=0.15±0.05mm
TREATMENT:
1. GOLD FLASH ON CONTACT AREA, MATTE SN 50u" MIN ON SOLDER TAIL, ALL OVER NI 30u" MIN.
2. GOLD 30u" MIN ON CONTACT AREA, MATTE SN 50u" MIN ON SOLDER TAIL, ALL OVER NI 30u" MIN.
1-3: SHELL: SUS(304); T=0.30±0.05mm, TREATMENT: 80u" TIN
2. SPECIFICATIONS:
2-1. CONTACT RESISTANCE: 30mΩ MAX
2-2. INSULATION RESISTANCE: 1000MΩ MIN.
2-3. DIELECTRIC WITHSTANDING VOLTAGE: 100V AC 60HZ 1MINUTE.
2-4. MATING AND UNMATING FORCE: MATING FORCE: 35N MAX/UNMATING FORCE: 8N MIN.
2-5. DURABILITY: 10000 CYCLES.

A
B
C
D
E
F

A
B
C
D
E
F

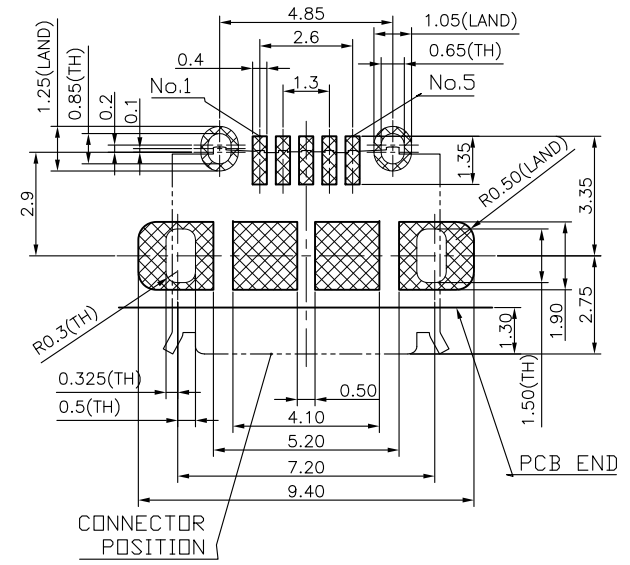
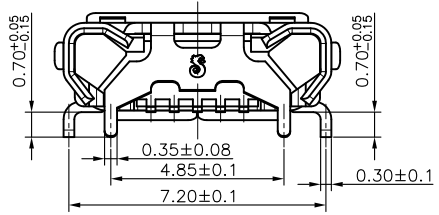
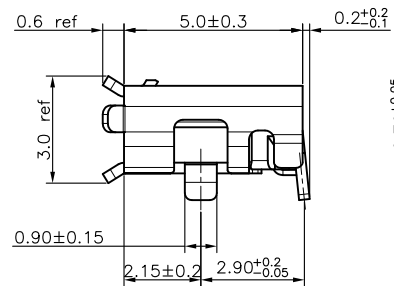
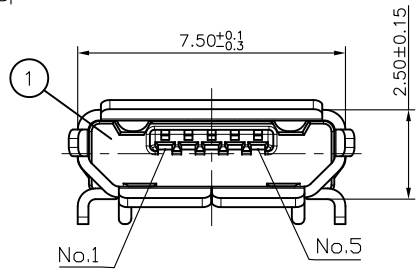
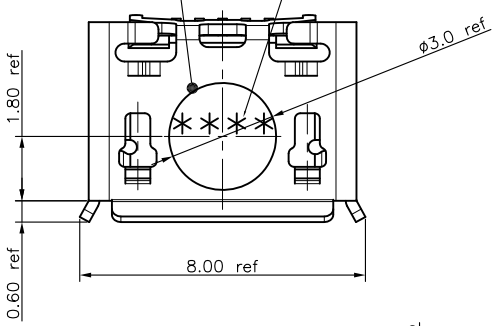

PCB LAYOUT
*General tolerance is ±0.05mm.

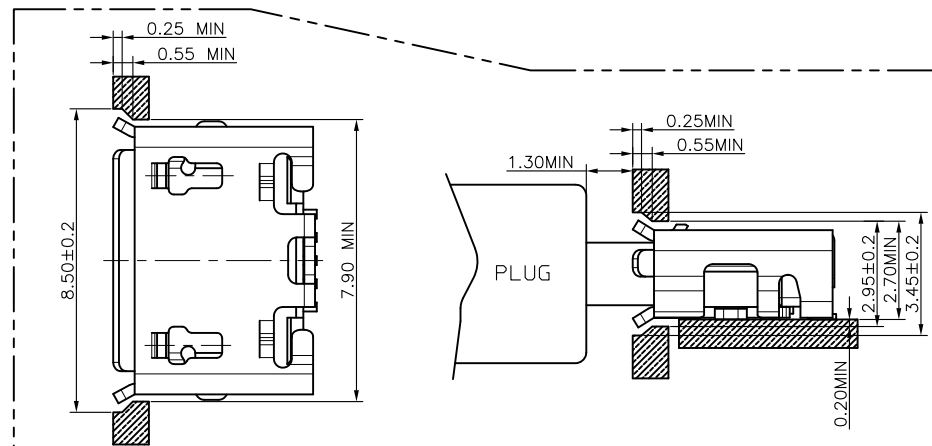
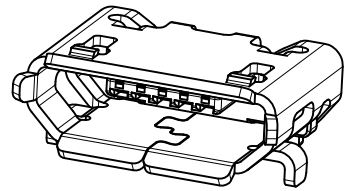
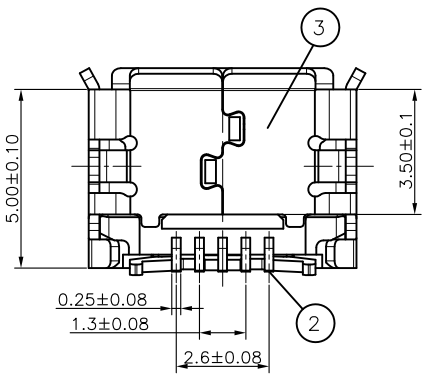

RECOMMENDED PANEL CUTOUT
MATED WITH CORRESPONDING PLUG

Part Number(客戶)
2UB1675-000111F

東莞世華電子有限公司
SHYH HWA ELECTRONICS CO.,LTD.(DONGGUAN)
地址: 東莞市塘廈鎮諸佛嶺178工業區
TEL: 0769-87910020-1 FAX: 0769-87910210

DRAWN BY	唐忠洪	ITEM	Micro usb 5P B type母座牛角 有档位, SMT全贴有卷边	ANGLE PROJECTION	UNIT	mm	
CHECKED BY					SCALE	Fit	
APPROVED BY		PART NO	CD0001042002-WLE21	TOLERANCE	.X±0.20 .XX±0.10	DATE	07/08/2015

1 2 3 4 5 6 7 8